

CCMT / Turning

Positive insert / rhomb 80°

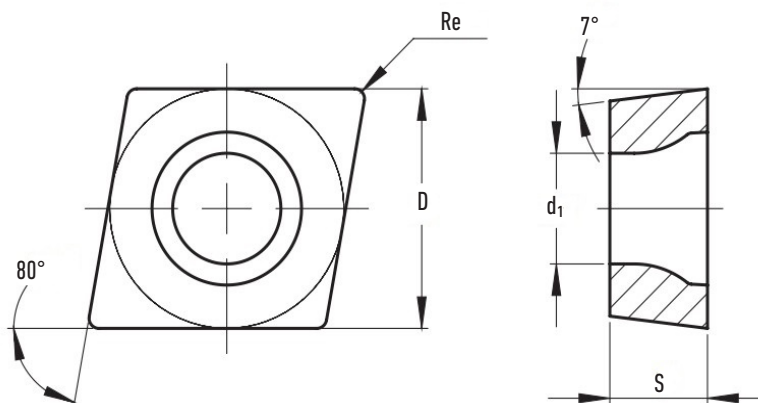

Code	Dimensions					Cutting conditions					
	D	S	Re	d ₁	A _p	A _{pmin.}	A _{pmax.}	F _z	F _{zmin.}	F _{zmax.}	
	(mm)					Chip depth (mm)			Feed (mm/t)		
CCMT09T302F	● ○	9,525	3,97	0,20	4,40	0,35	0,08	2,00	0,08	0,04	0,13
CCMT09T304F	● ○	9,525	3,97	0,40	4,40	0,35	0,11	2,00	0,11	0,06	0,23